



DISPLAY
CONCEPTS

Next Mini

Refrigerated & Confectionery Showcase H95



Features: Next Mini is a single-level jewelry-style showcase that displays and enhances the value of your products. Mini is perfect for chocolate, small assorted pastries and top quality refrigerated foods.

Tubular structural aluminum base with adjustable feet. Rear uprights in aluminum, front uprights in Plexiglas with embedded LED lighting. Automatic defrosting controlled by electronic thermostat. LED lighting mounted on top enhance the display surface.

The display compartment is accessed via the top glass panel which slides open on a machined ball-bearing track. The curved front glass of the display compartment opens from the front for easy cleaning.

Mini comes standard with white lacquered side and front glass panels, but can be customized to a wide variety of optional finishes and RAL colors.

Mini cases can be channeled together and are suitable for in-line installation. Remote compressors can be supplied upon request.

Front glass: curved panel opens for easy cleaning

Top glass: slides open on machined track

Glass panels: all glass is tempered

Front & side base panels: white lacquered glass - optional covers available in a variety of finishes and RAL colors

Compressor: available internal or remote

Defrosting: automatic electric defrost with thermostat control

Lighting: ultra-bright LED

Electric: 220V 15A 1Phase

Plumbing: none required with internal compressor

REFRIGERATED – VENTILATED SHOWCASE

Operating temperature +37°F/+44°F (+3°C/+7°C)

Climate Class 3 (25°C - 60% R.H.)

CONFECTIONERY SHOWCASE

Operating Temperature +57°F/+61°F
(+14°C/+16°C)

Climate Class 4 (30° C- 55% R.H.)



info@fmdisplayconcepts.com
800-889-3975
www.fmdisplayconcepts.com

Next Mini

Refrigerated & Confectionery Showcase



REFRIGERATED – VENTILATED SHOWCASE

Operating temperature +37°F/+44°F (+3°C/+7°C)

Climate Class 3 (25°C - 60% R.H.)

CONFECTIONERY SHOWCASE

Operating Temp. +57°F/+61°F(+14°C/+16°C)

Climate Class 4 (30° C- 55% R.H.)

Next Mini showcases are designed to perform best when full of product, and for ambient conditions not higher than 75°F and 55% relative humidity. Do not install near, or in-line with windows, doors, HVAC vents or fans as these will interfere with air circulation and effect the performance of the case.

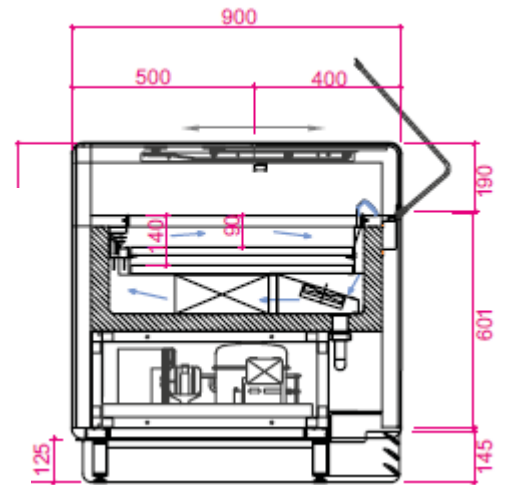

Top View
Operator Side

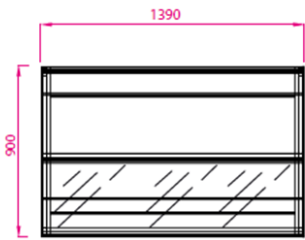

1350

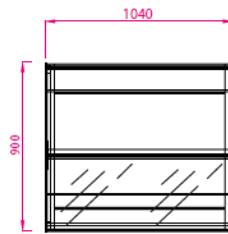

1000

Feature	inches	mm	HP	Watt	Circ. Amp
Depth (All)	35.4	900			
Height (All)	37.4	950			
Length (1000)	40.9	1040	1/3	412	15
Length (1350)	54.7	1390	3/8	482	15

frigomeccanica

CE

ETL LISTED

 Intertek Intertek
 3094110
 CONFORMS TO UL STD 471; NSF STD 7
 CERTIFIED TO CAN/CSA C22.2 STD No. 120

