

# Fusion

## Gelato & Ice Cream Showcase



**Features:** Professional ventilated gelato & ice cream showcase with two shelves in tempered glass. Tubular epoxy-painted steel base. Rigid body lined in stainless steel, insulated with injected polyurethane. Base is fitted with adjustable feet or optional wheels. Curved tempered front glass is heated and opens downward. Glass superstructure is constructed of painted aluminum. Tempered glass front & sides, heated with panel control with electronic regulation. Rear enclosed by Plexiglas sliders. Refrigerating system with evaporator installed underneath the display surface. Single compressor on 12 pan showcases, double compressor on all larger showcases. Automatic reverse cycle defrost. LED lighting standard. Automatic condensation evaporation on showcases with internal compressor (connected to the drain with remote).

**Structure:** tubular epoxy-painted steel, stainless steel & aluminum

**Front glass:** downward opening on hinge

**Display surface:** stainless steel

**Glass panels:** tempered and heated

**Front & side base panels:** available in a variety of finishes and RAL colors

**Compressor:** available internal or remote

**Defrosting:** reverse cycle with electronic control

**Lighting:** high luminosity LED

**Electric:** Electric: 220V 1Phase. See next page for Amperage

**Plumbing:** condensate drain with remote compressor



FUSION GELATO & ICE CREAM SHOWCASE

**Operating temperature** 0°F/+10°F (-18°C/-12°C)

**Climate Class 4** (30° C- 55% R.H.)

info@fmdisplayconcepts.com

800-889-3975

www.fmdisplayconcepts.com

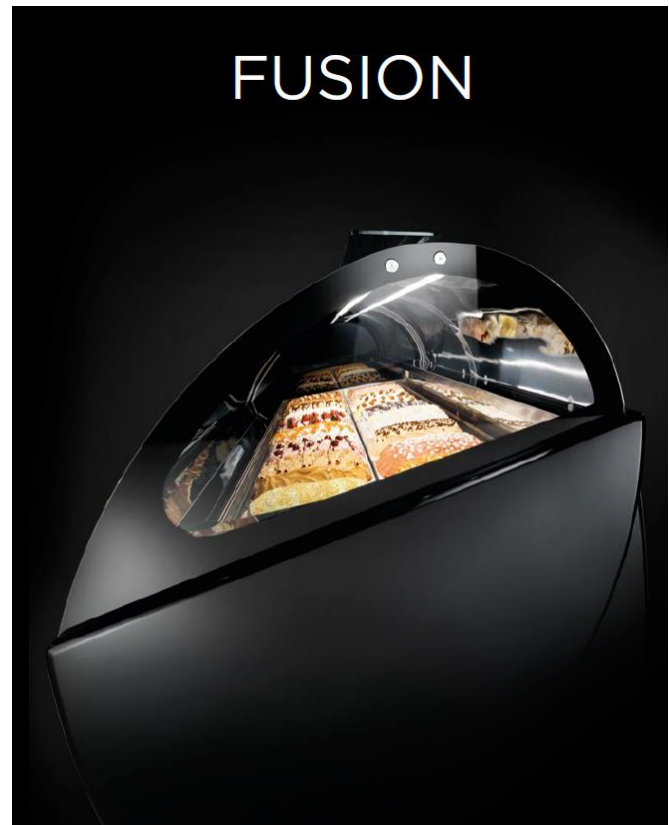



# Fusion

## Gelato & Ice Cream Showcase

Top View  
Operator Side

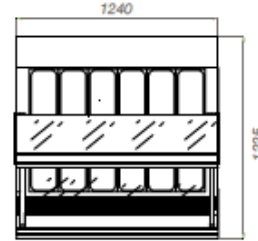
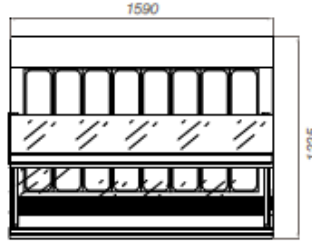
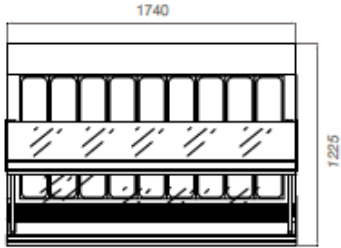

18

16

12

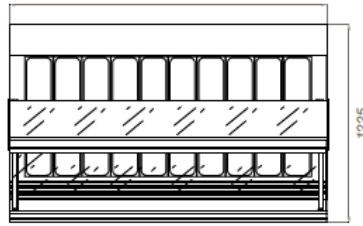
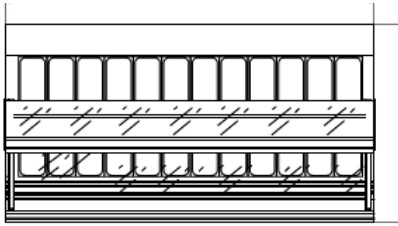

24

20

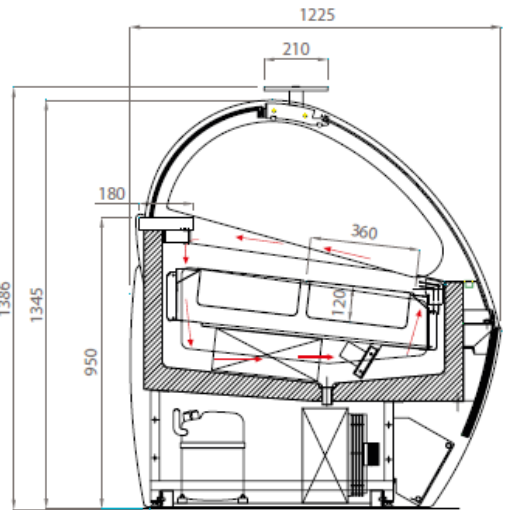

Feature	inches	mm	HP Internal	Watt Int.	Circ. Amp	Tubs 5 L
Depth (All)	48.2	1225				
Height (All)	54.6	1386				
Length (12 pan)	48.8	1240	1 1/2	2210	20	12
Length (16 pan)	62.6	1590	2 x 1 HP	2980	30	16
Length (18 pan)	68.5	1740	2 x 1.2	3050	30	18
Length (20 pan)	76.4	1940	2 x 1.5	3060	30	20
Length (24 pan)	88.2	2240	2 x 1.5	4510	30	24

Fusion Gelato showcases are designed to perform best when full of product, and for ambient conditions not higher than 75°F and 55% relative humidity. Do not install near, or in-line with, windows, doors, HVAC vents or fans as these will interfere with air circulation and affect the performance of the case.



Intertek 3094110  
CONFORMS TO UL STD 471; NSF STD 7  
CERTIFIED TO CAN/CSA C22.2 STD No. 120

