



DISPLAY
CONCEPTS

Visual

Refrigerated Pastry Showcase

H147



Features: Ventilated professional pastry showcase with sloping display. Front glass opens with hydro-lift pistons. Bottom level refrigerated, top 3 shelves ambient. Sides and front in tempered, heated glass, with panel control on operator side. Ventilated refrigeration system with adjustable speed fan, automatic defrost during stoppage, control panel in the top section (operator's side). Risers and front grill in anodized aluminum (gold or champagne optional). High-intensity LED lighting standard. Automatic condensation evaporator on showcases with internal motor, (connection to the main drain system for showcases with remote motor.) Can be channeled to the VISUAL gelato & ice cream showcase. Rear of case closes with rollaway blind, supplied as standard.

VISUAL REFRIGERATED – VENTILATED SHOWCASE

Operating temperature +32°F/+41°F (0°C/+5°C)

Climate Class 4 (30° C- 55% R.H.)

Relative Humidity 55% -60%

Structure: stainless steel & anodized aluminum with sanded finish

Front glass: piston opening

Glass panels: tempered and heated

Front & side base panels: lacquered in a variety of RAL colors; side panel with insert

Compressor: available integral or remote

Defrosting: automatic at motor stop

Lighting: high-intensity LED standard

Electric: 220V 15A 1Phase

Plumbing: none required



info@fmdisplayconcepts.com
800-889-3975
www.fmdisplayconcepts.com



Visual Refrigerated Pastry Showcase

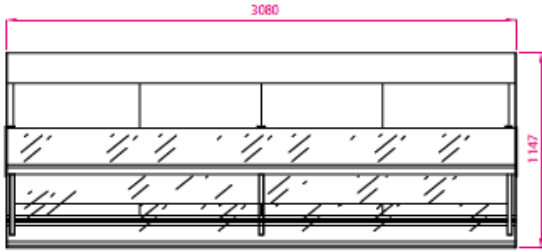

3000

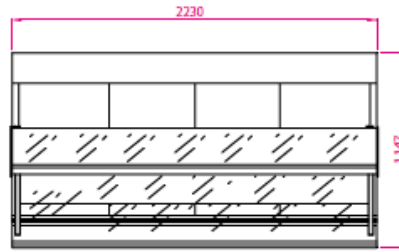

2150

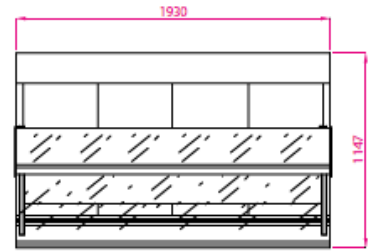

1850

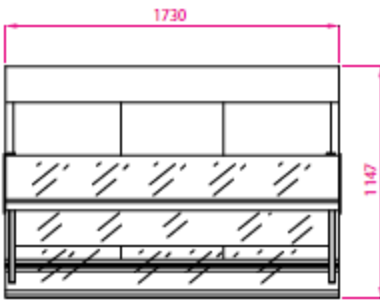

1650

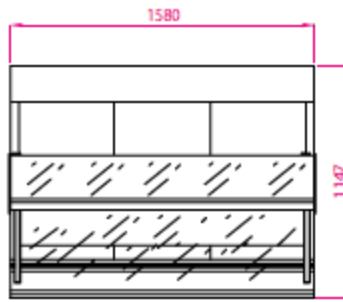

1500

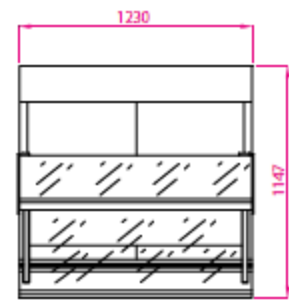

1150

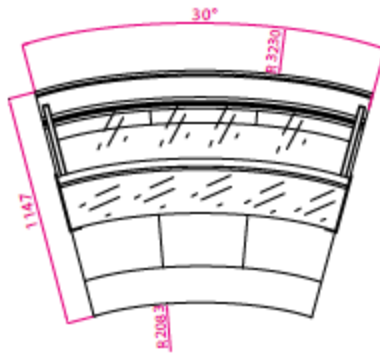

ANGOLO INTERNO 30°

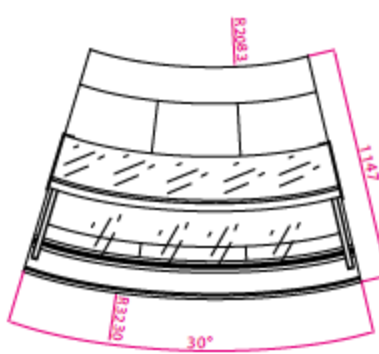

ANGOLO ESTERNO 30°

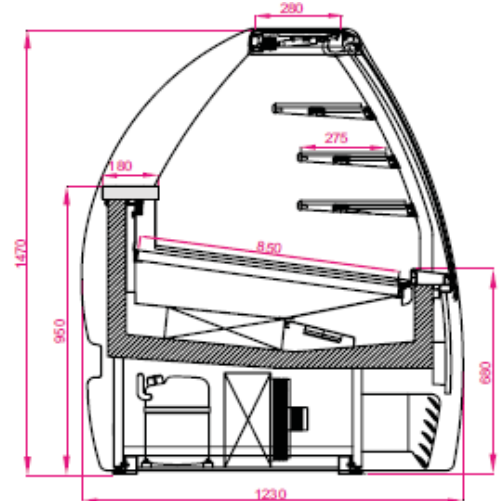

Feature	inches	mm
Depth (All)	45.2	1147
Height (All)	57.9	1470
Length (1150)	48.4	1230
Length (1500)	62.2	1580
Length (1650)	68.1	1730
Length (1850)	76.0	1930
Length (2150)	87.8	2230
Length (3000)	121.3	3080

ETL LISTED
 US
 Intertek
 3094110
 CONFORMS TO UL STD 471; NSF STD 7
 CERTIFIED TO CAN/CSA C22.2 STD No. 120



frigomeccanica
Arredamenti Bar